



VESTIDO EVASÉ



Visita lolaguindilla.com para más patrones y tutoriales



ANTES DE EMPEZAR

ENCUENTRA TU TALLA

Usa el cuadro de tallas para encontrar la que mejor se ajuste a ti. Si estás entre dos tallas, escoge la mayor.

MONTA EL PATRÓN COMPLETO

En la página 3 se muestra el patrón completo, con el número de piezas que engloba y cómo están dispuestas. Imprime las hojas en formato A4 (folio) y únelas por las marcas con código número - letra iguales. Pégalas con celofán.

Recuerda comprobar el cuadrado de comprobación de medidas, que debe ser de 10 cm x 10 cm.

Una vez tengas el patrón montado, elige un rotulador de color y marca las líneas correspondientes a tu talla. Corta por las líneas marcadas.

TABLA TALLAS DE MUJER

	36	38	40	42	44	46	48	50
Contorno pecho	80	84	88	92	96	100	104	108
Contorno cintura	58	62	66	70	74	78	82	86
Contorno cadera	86	90	94	98	102	106	110	114
Ancho espalda	36	37	38	39	40	42	44	45
Alto pecho	23,5	24	24,5	25,5	26	26,5	27,5	28
Altura cadera	18	18,5	19	19,5	20	20,5	21	21,5
Largo talle delantero	42,5	43	43,5	44,5	45	45,5	46,5	47
Largo talle espalda	41	41,5	42	42,5	43	43,5	44	44,5
Largo manga	58	58,5	59	59,5	60	60,5	61	61,5
Tiro	63	64,5	66	67,5	69	70,5	72	73,5

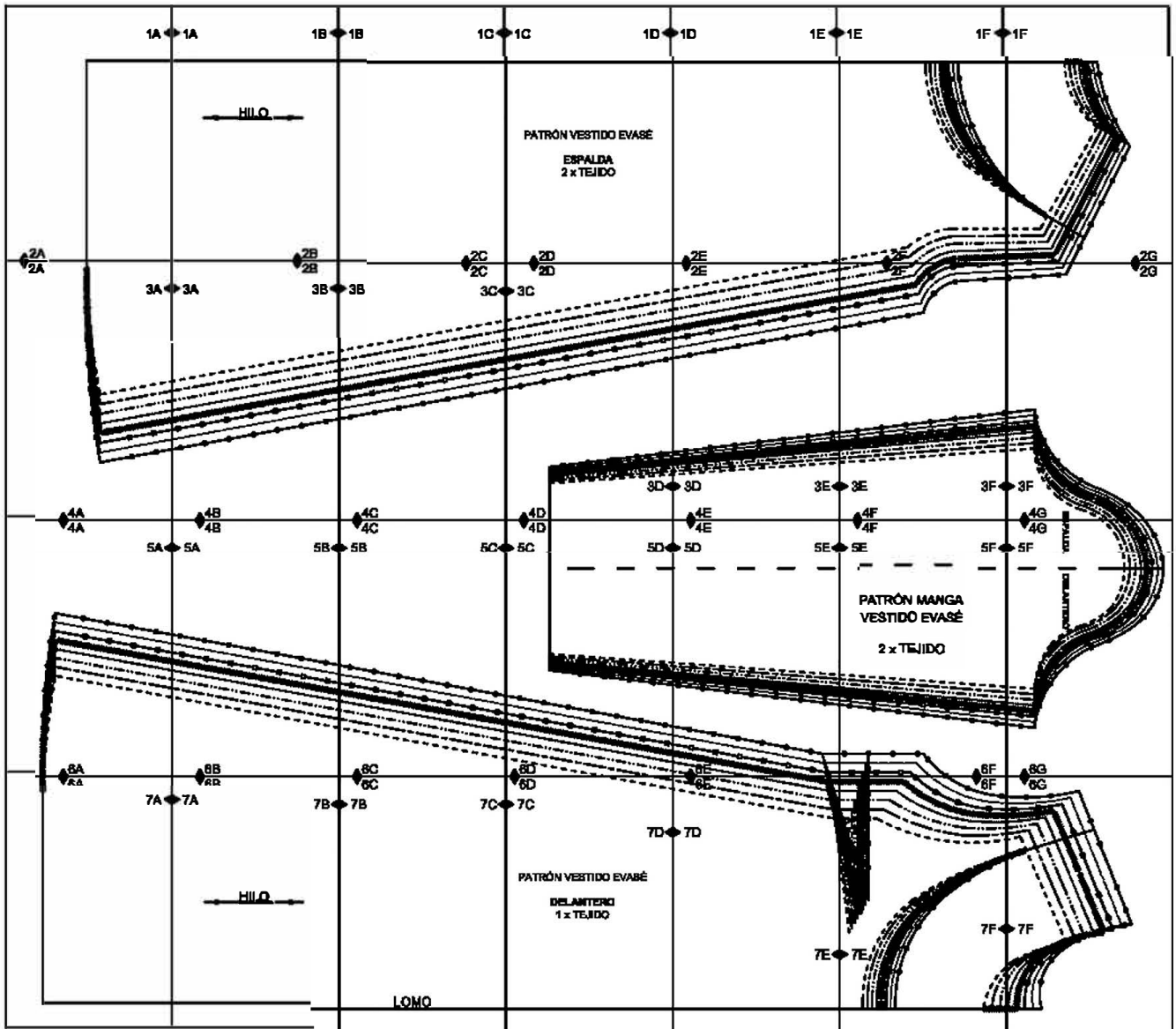

LEYENDA TALLAS

- TALLA 36
- TALLA 38
- TALLA 40
- TALLA 42
- TALLA 44
- TALLA 46
- TALLA 48
- TALLA 50
- COMÚN A TODAS LAS TALLAS



LEYENDA TALLAS

-----	TALLA 36
-----	TALLA 38
-----	TALLA 40
-----	TALLA 42
=====	TALLA 44
-----	TALLA 46
-----	TALLA 48
-----	TALLA 50
-----	COMÚN A TODAS LAS TALLAS

TEST COMPROBACIÓN
MEDIDAS

CUADRADO DE MEDIDAS
10 cm x 10 cm

1A 

 2A

▶ 1A

1B ◀

◀ HILO ▶

▶ 2B

▶ 1B

1C ◀

▲ 2C

▶ 1C

1D ◀

PATRÓN VESTIDO EVASÉ

ESPALDA
2 x TEJIDO

◀ 2D

▶ 1D

1E ◀

▲ 2E

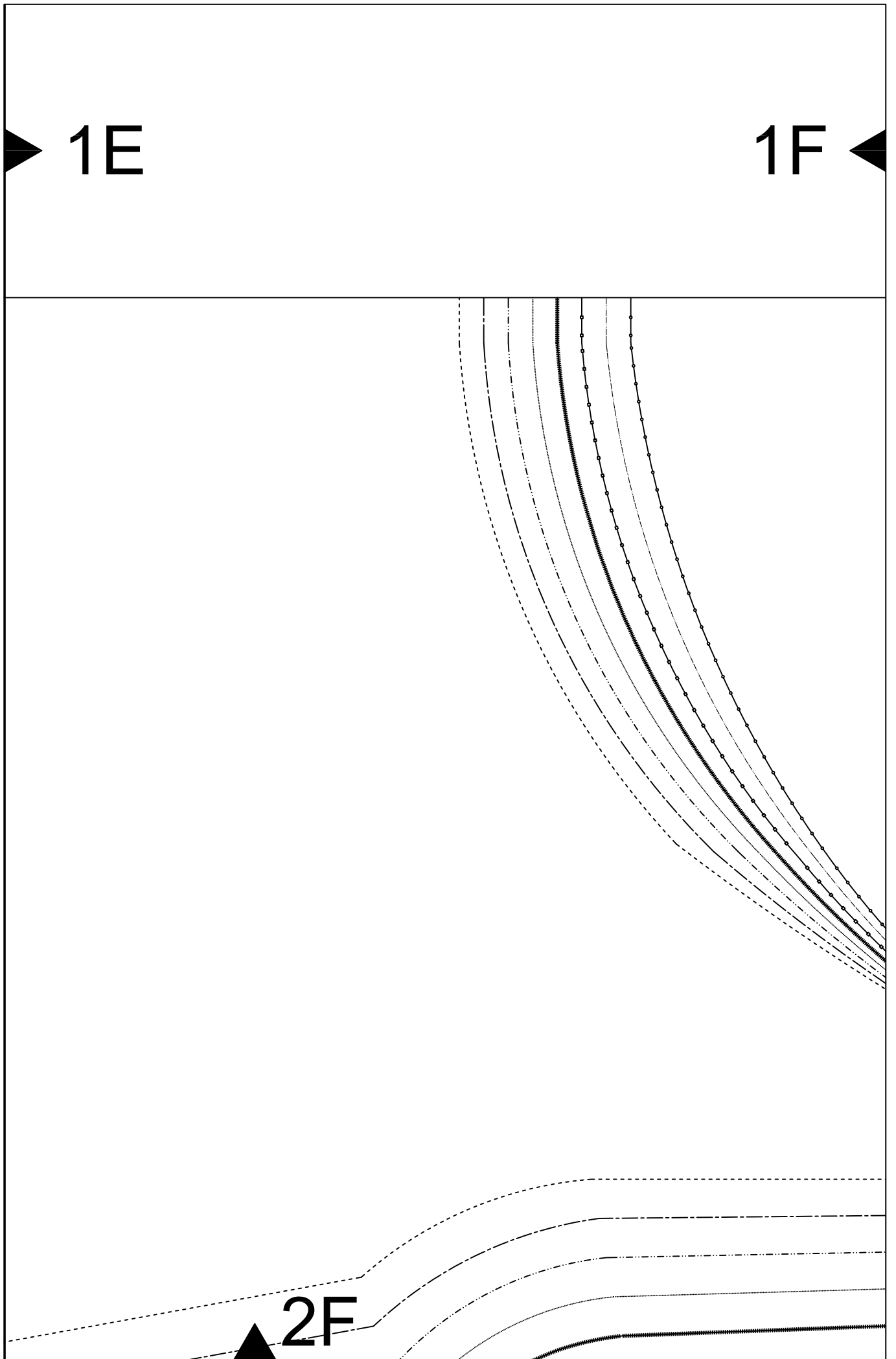

▶ 1F

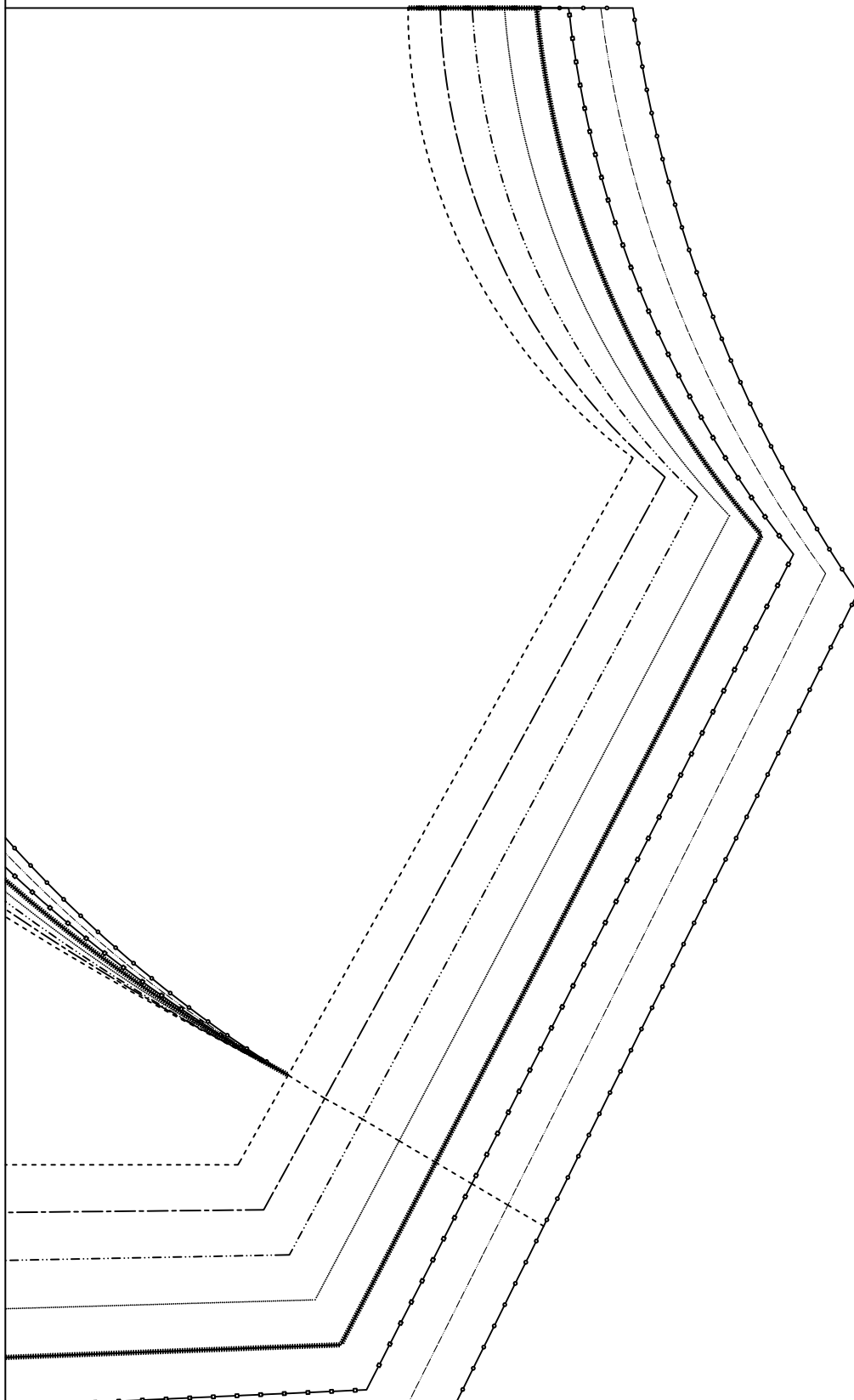

▶ 2G

2A

3A

4A

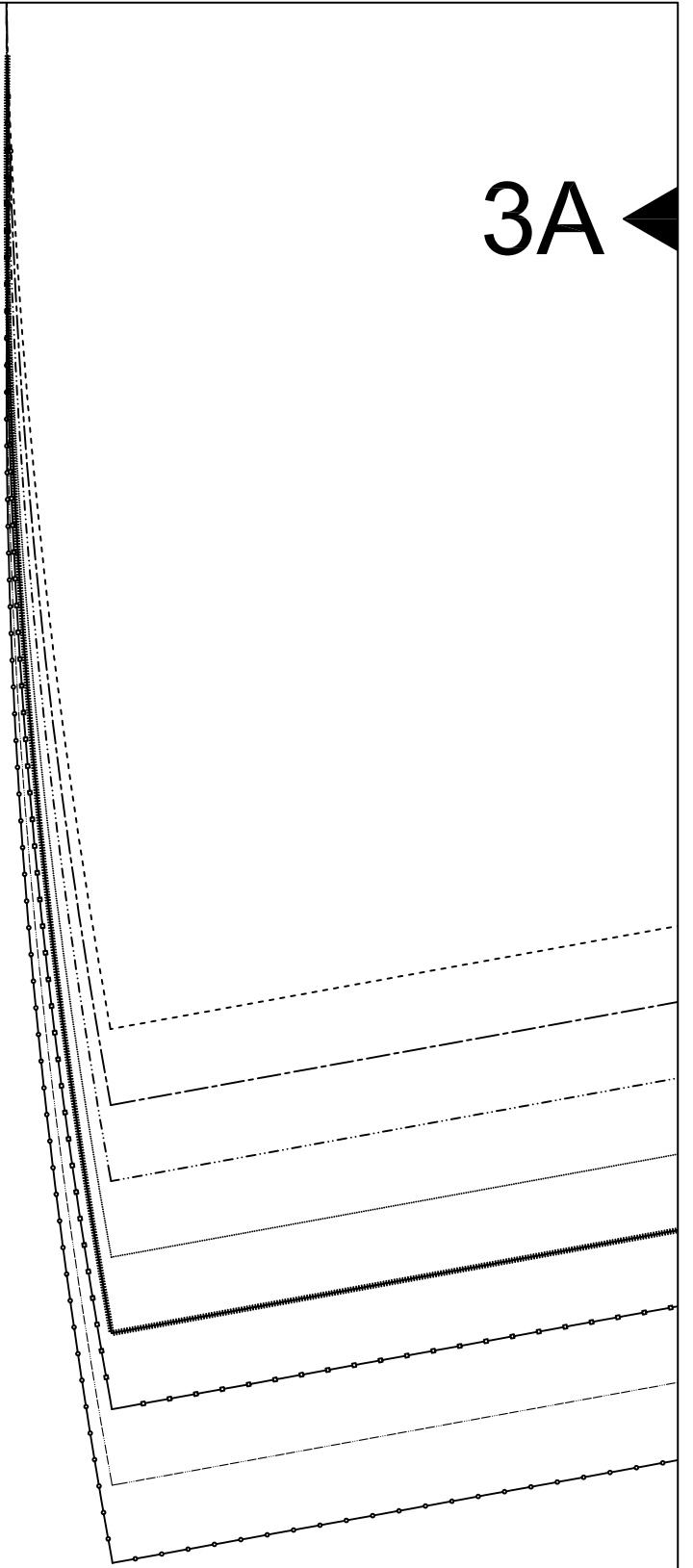

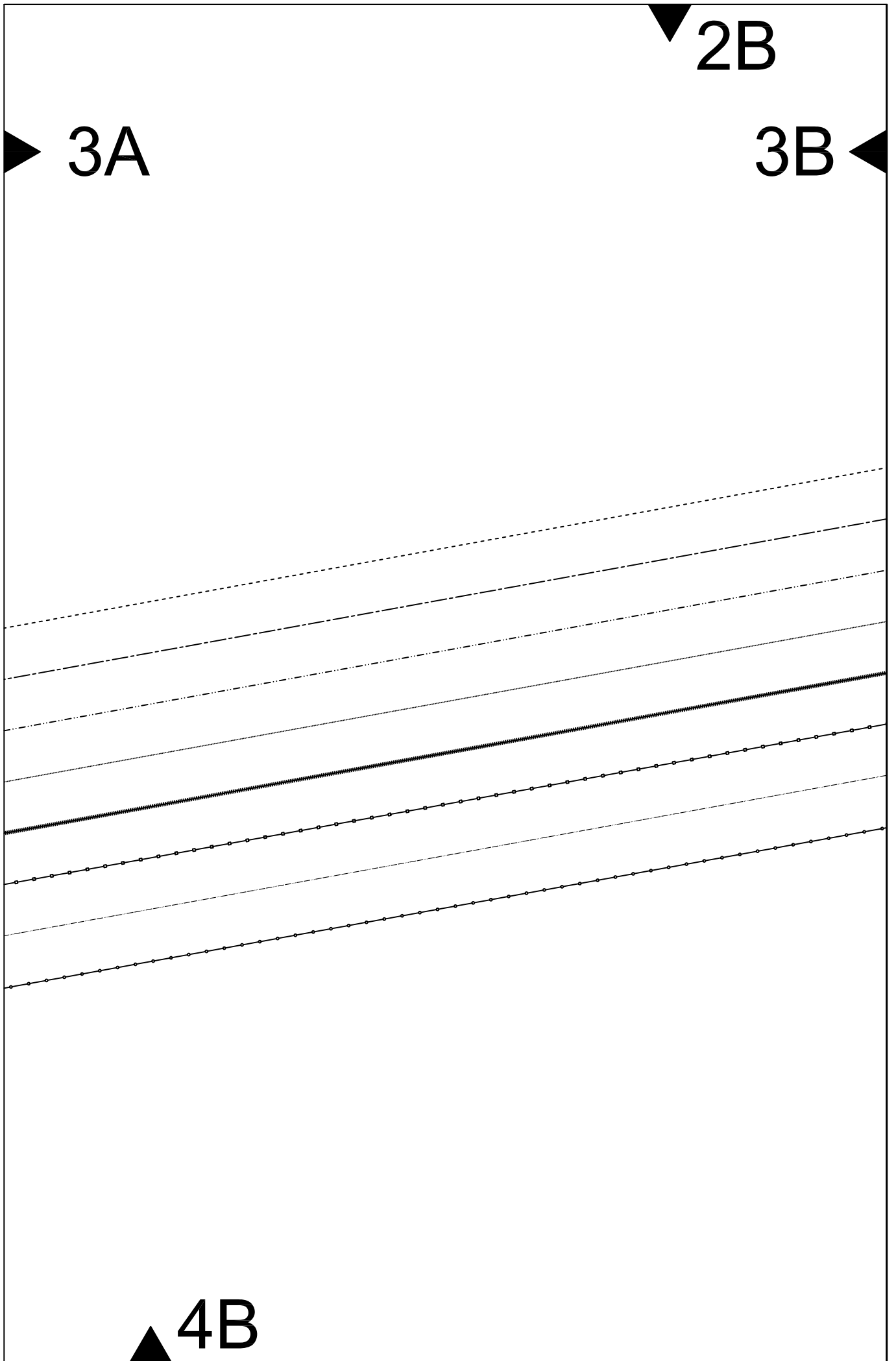

2C

3B

3C

4C

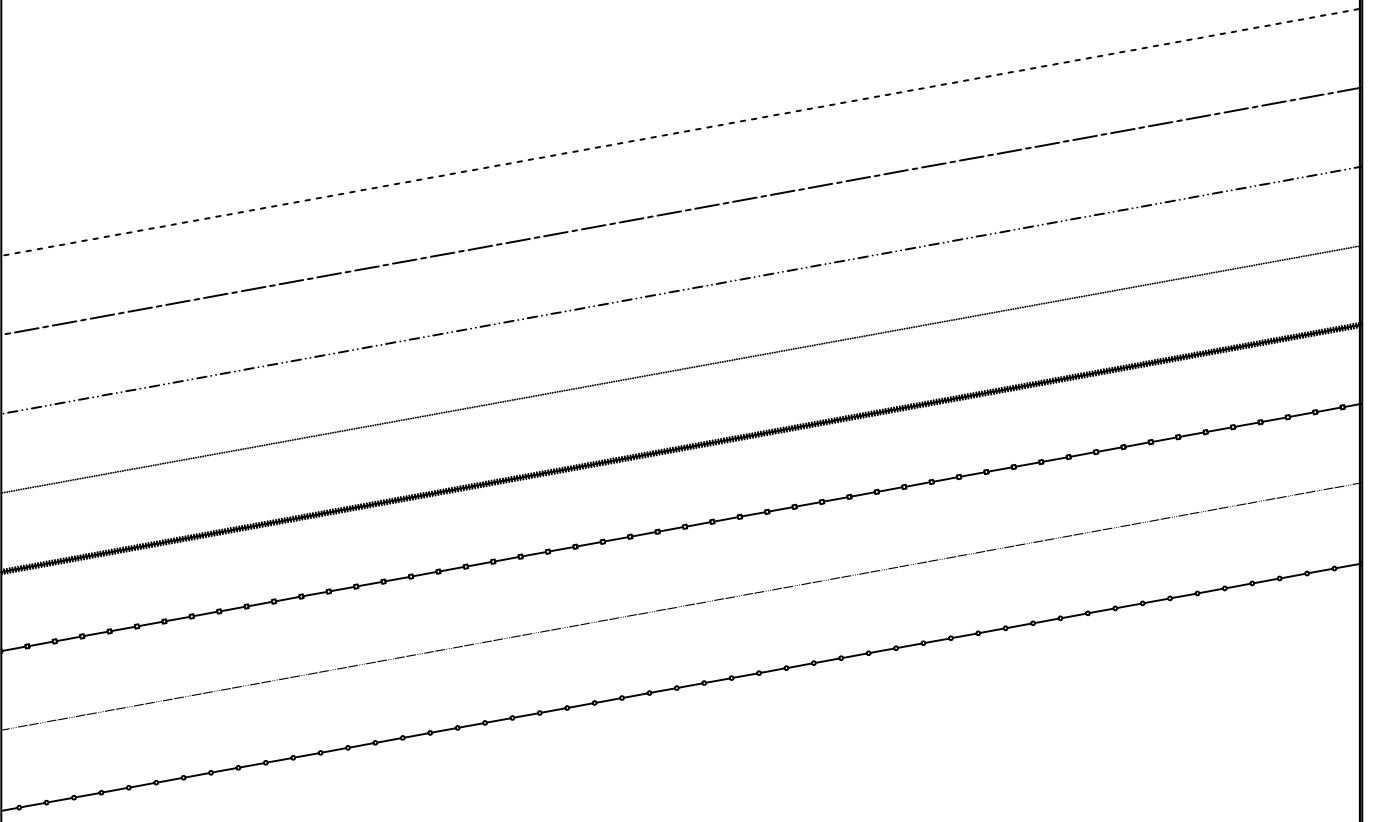

2D

3C

3D

4D

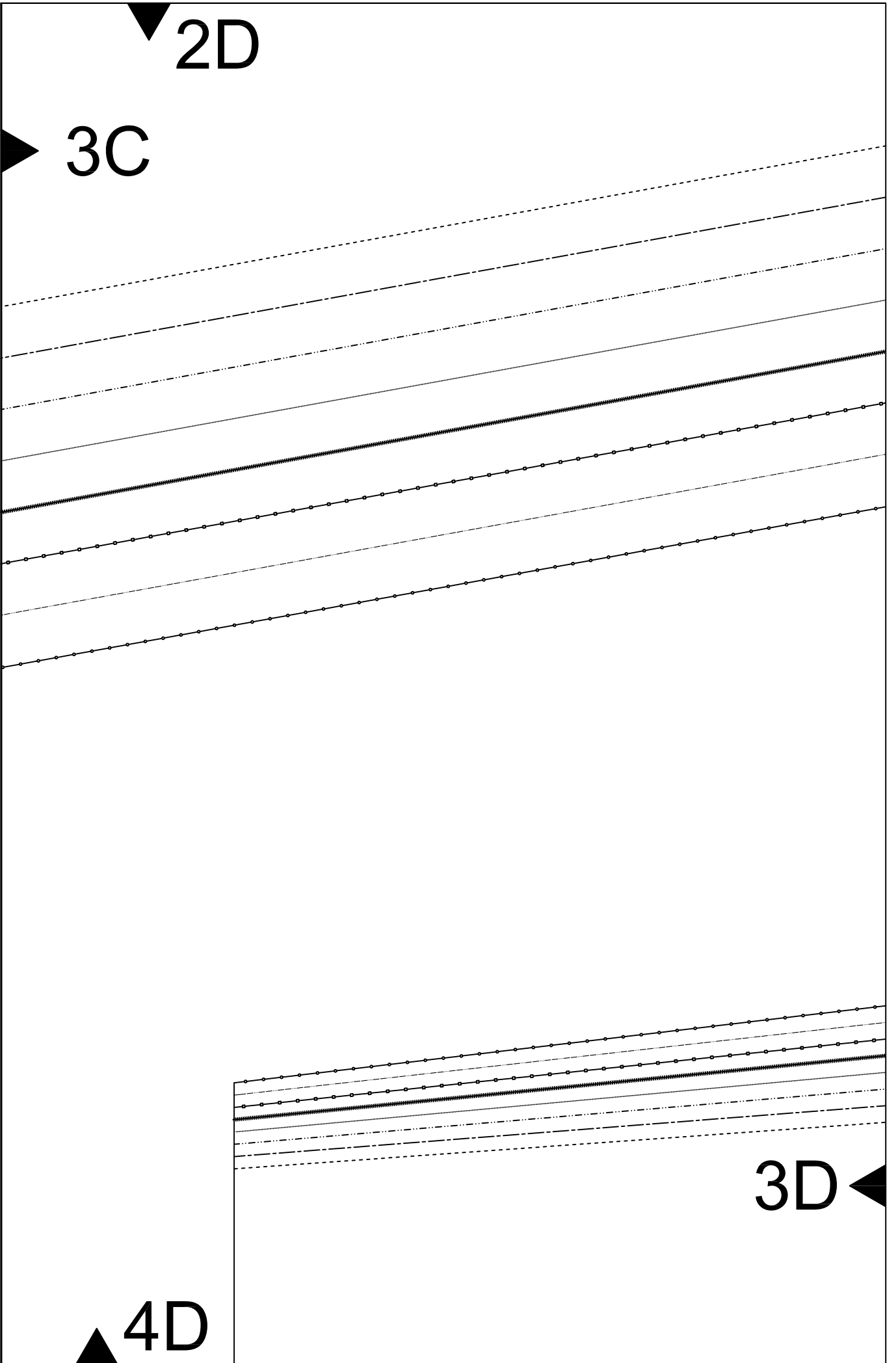

▼ 2E

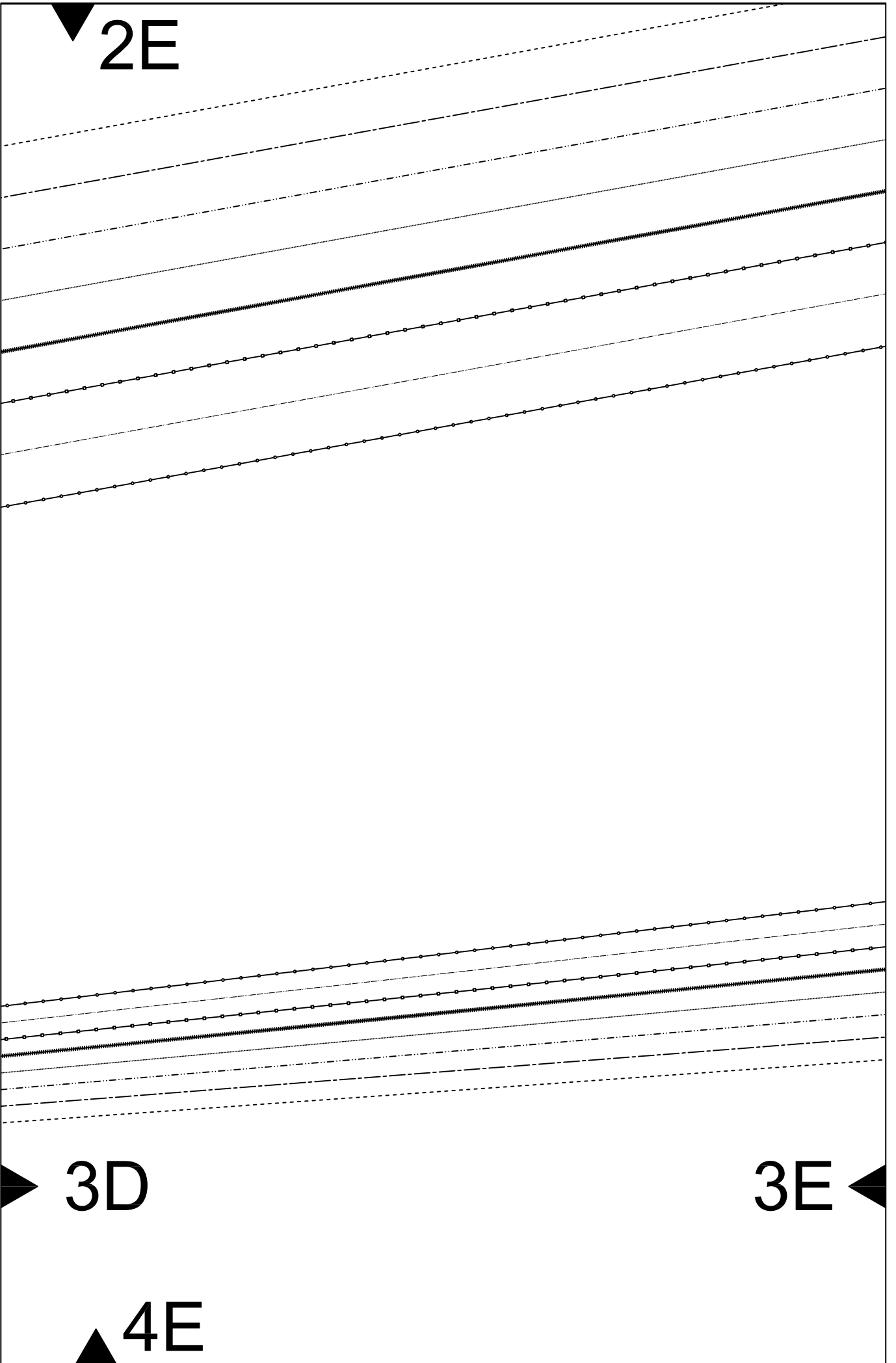

▶ 3D

3E ◀

▲ 4E

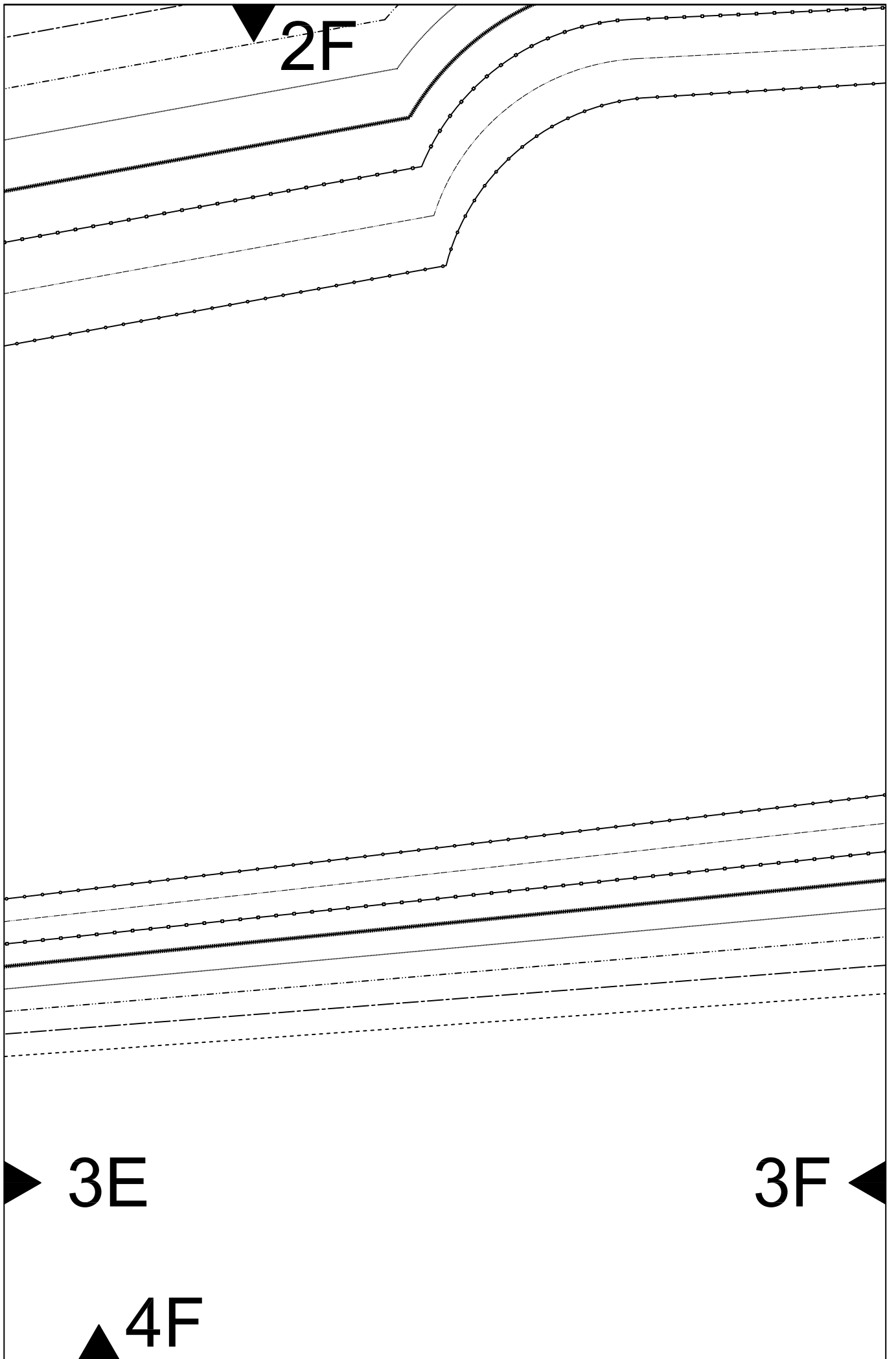

▼ 2G

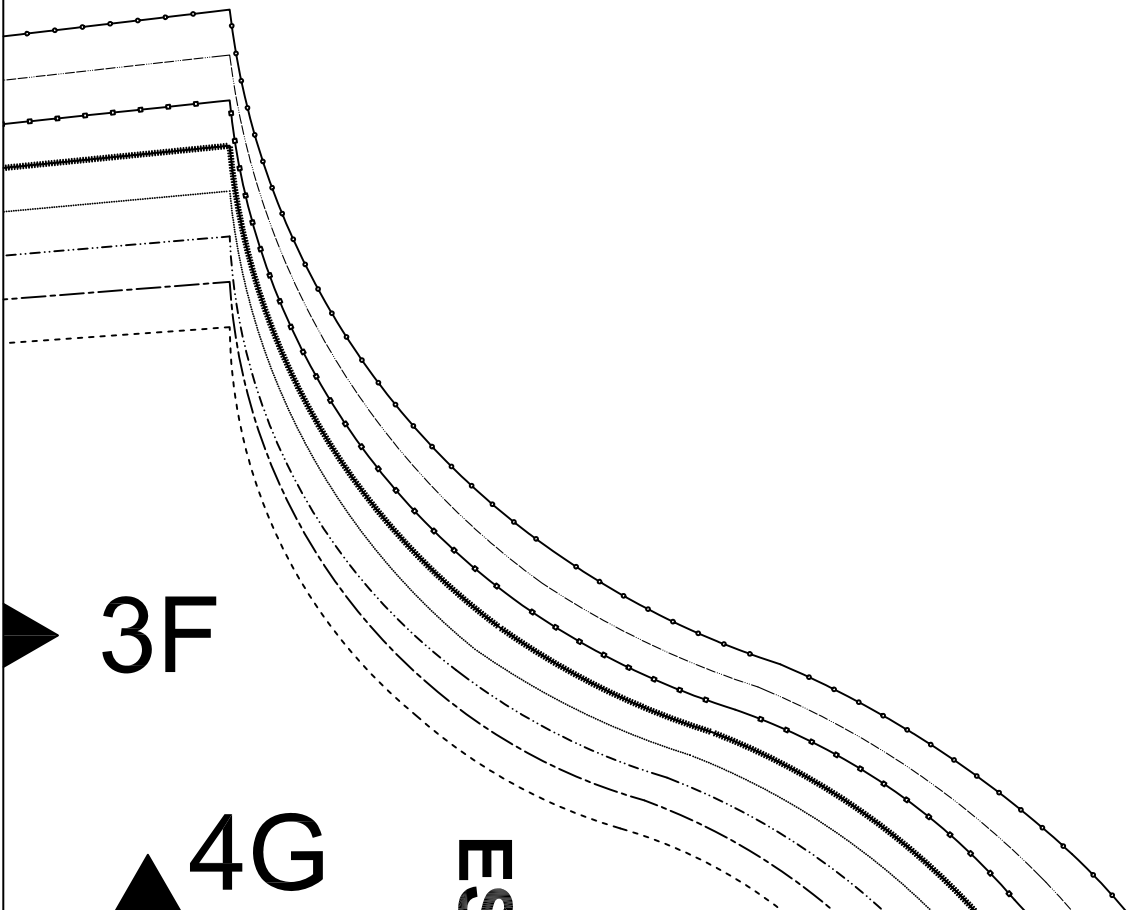

▶ 3F

▲ 4G

ES

4A

5A

6A

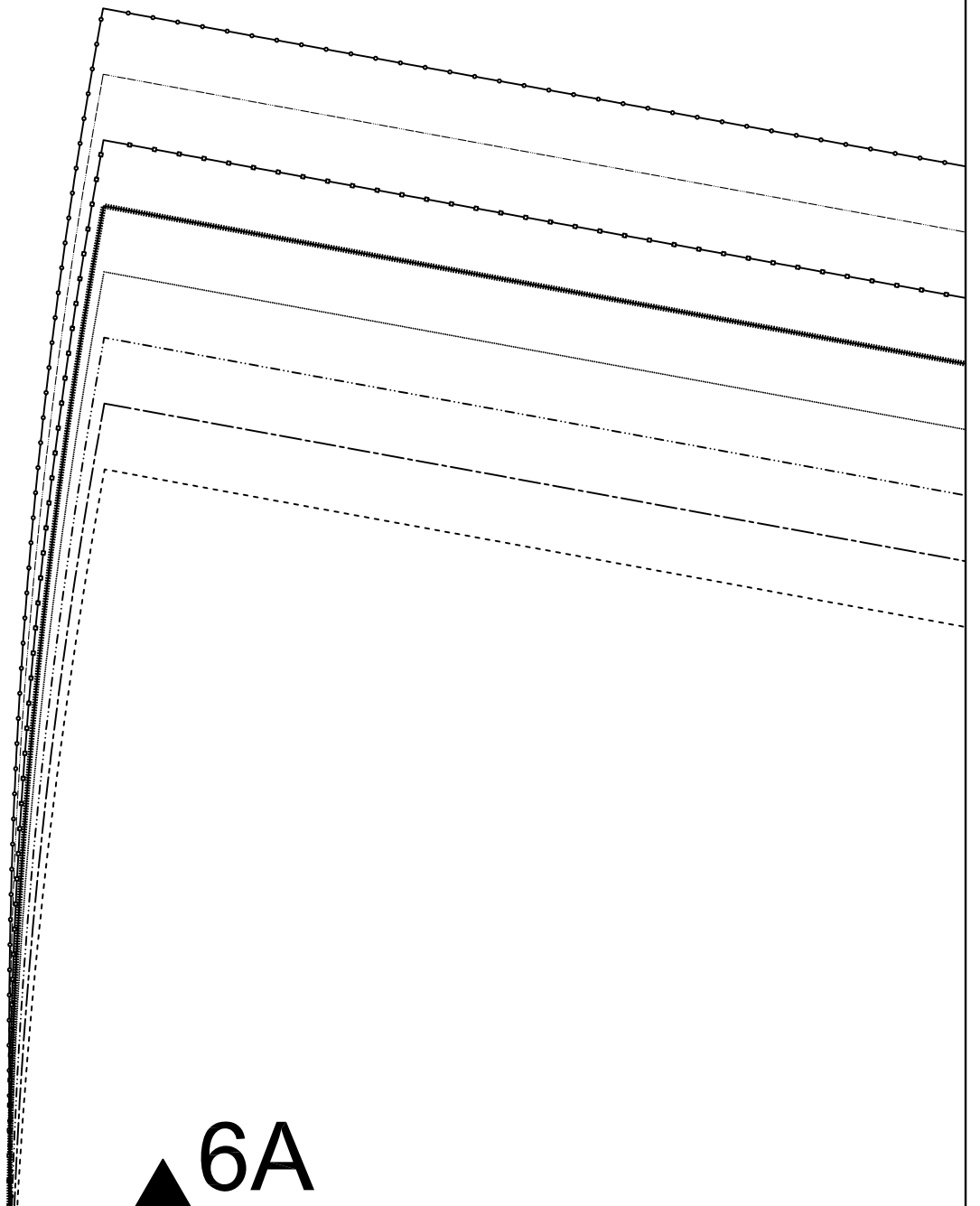

4B

5A

5B

6B

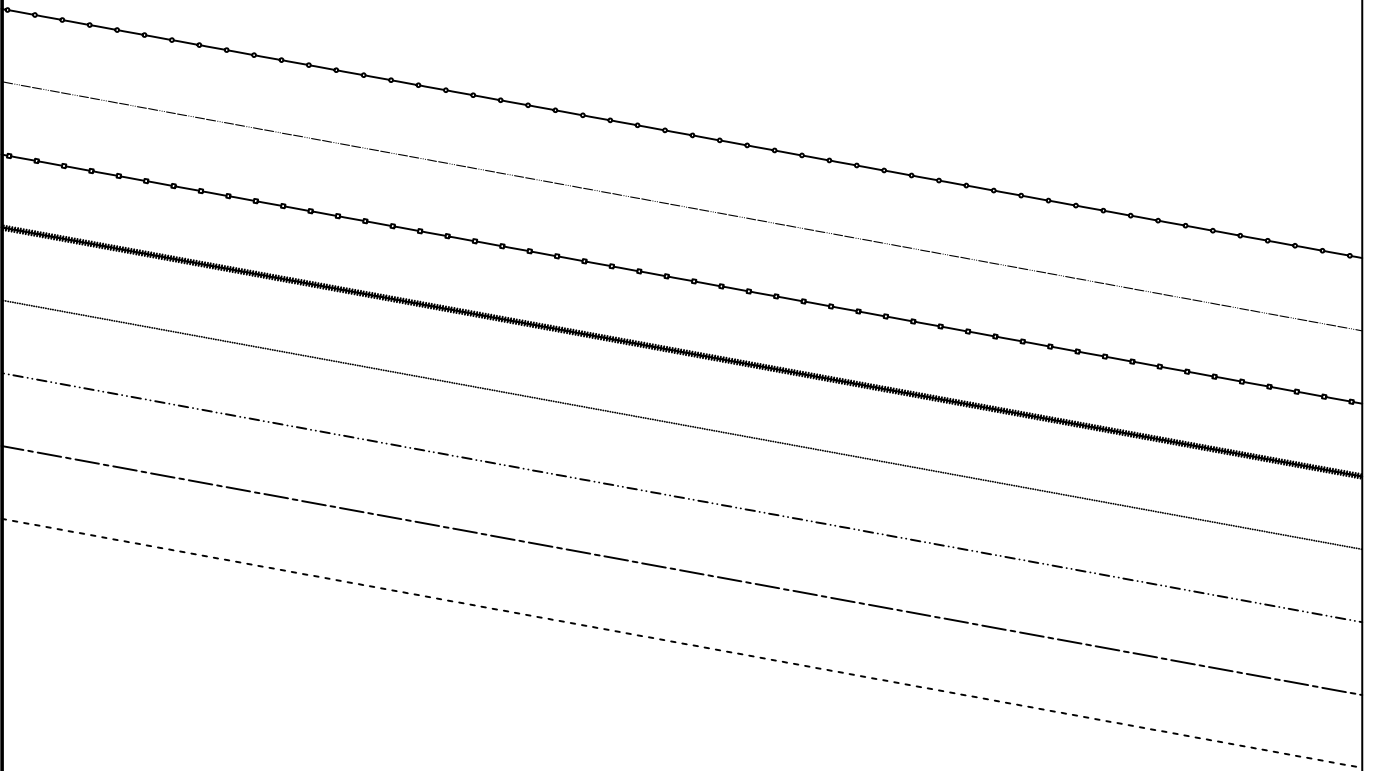

4C

5B

5C

6C

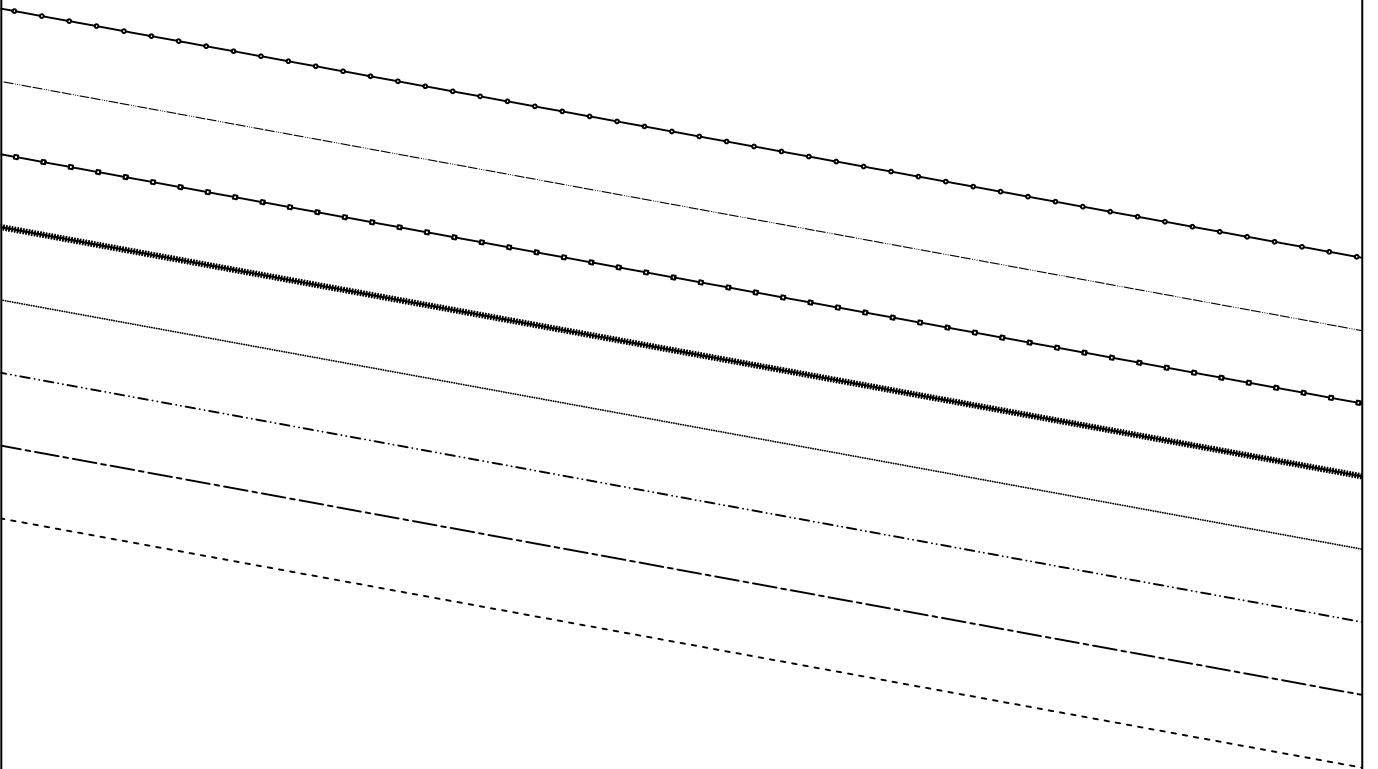

4D

5C

5D

6D

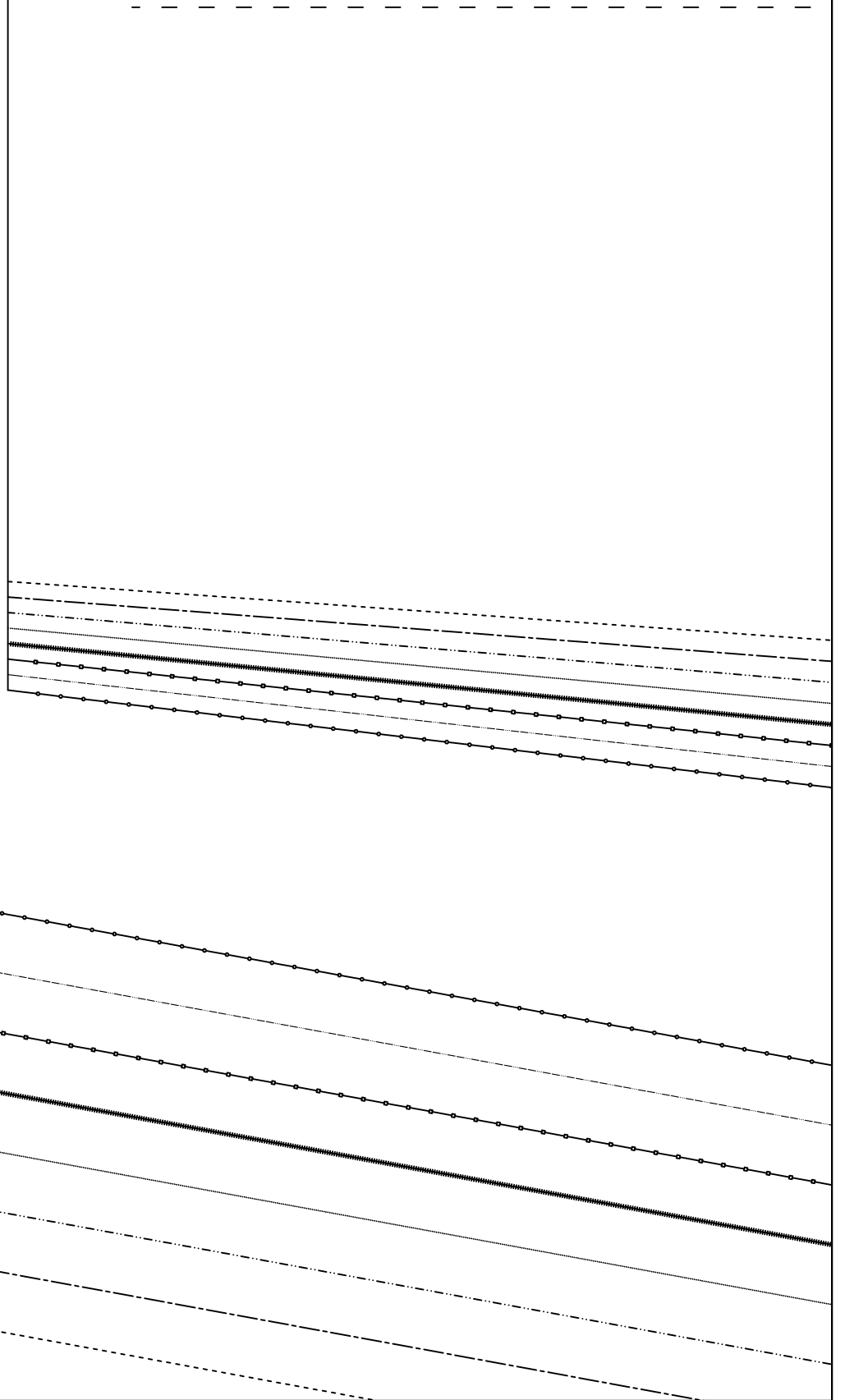

4E

5D

5E

6E

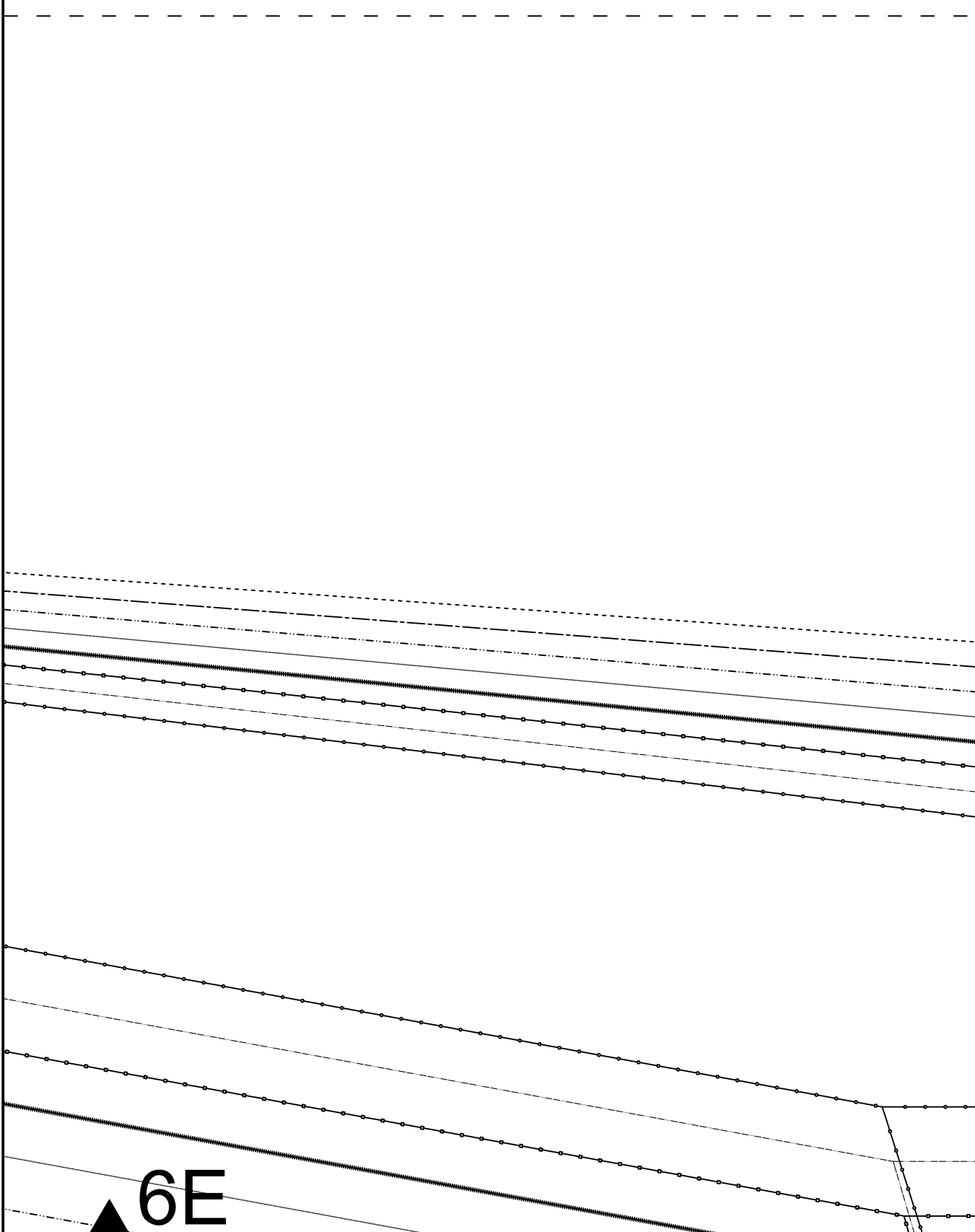

4F

5E

5F

PATRÓN MANGA
VESTIDO EVASÉ

2 x TEJIDO

6F

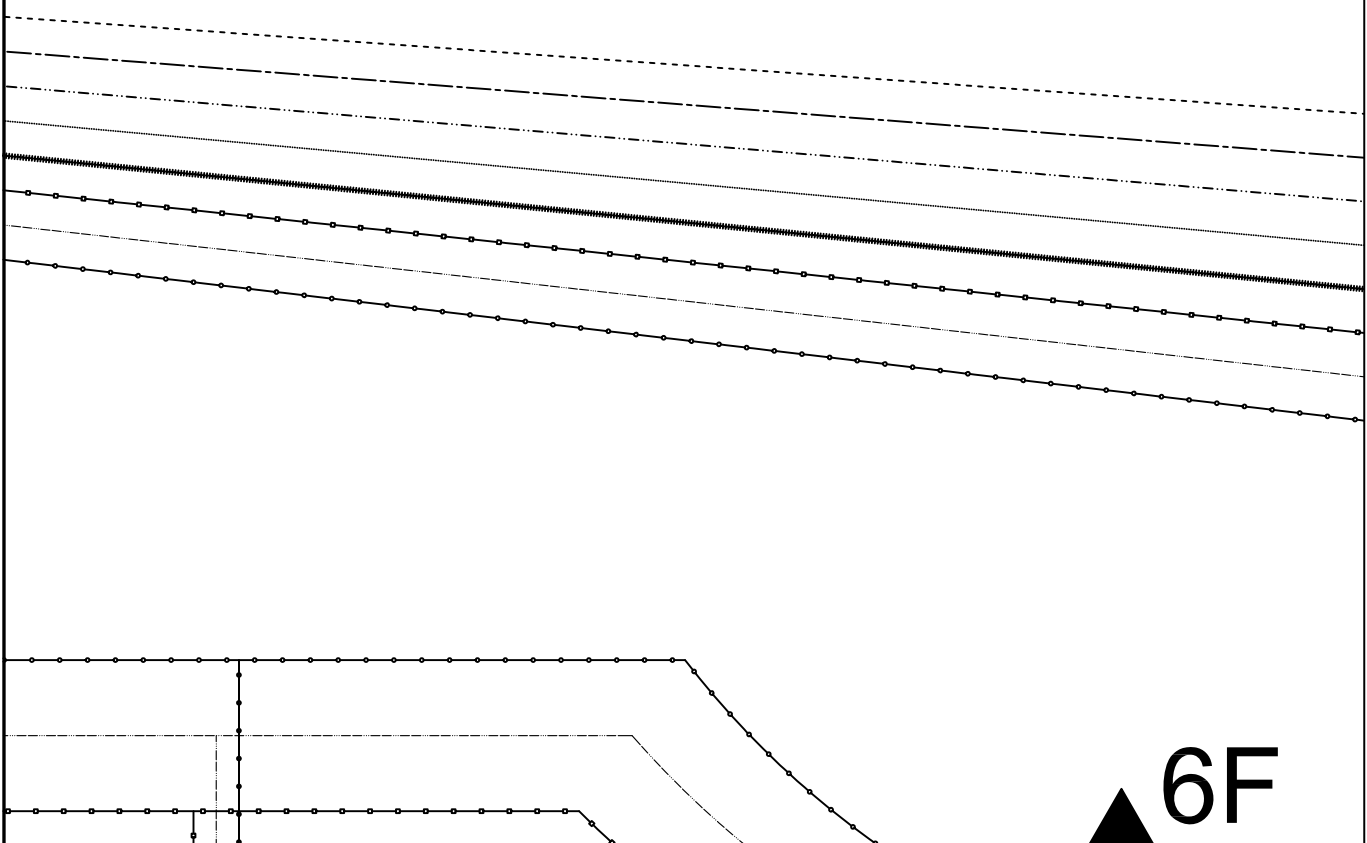

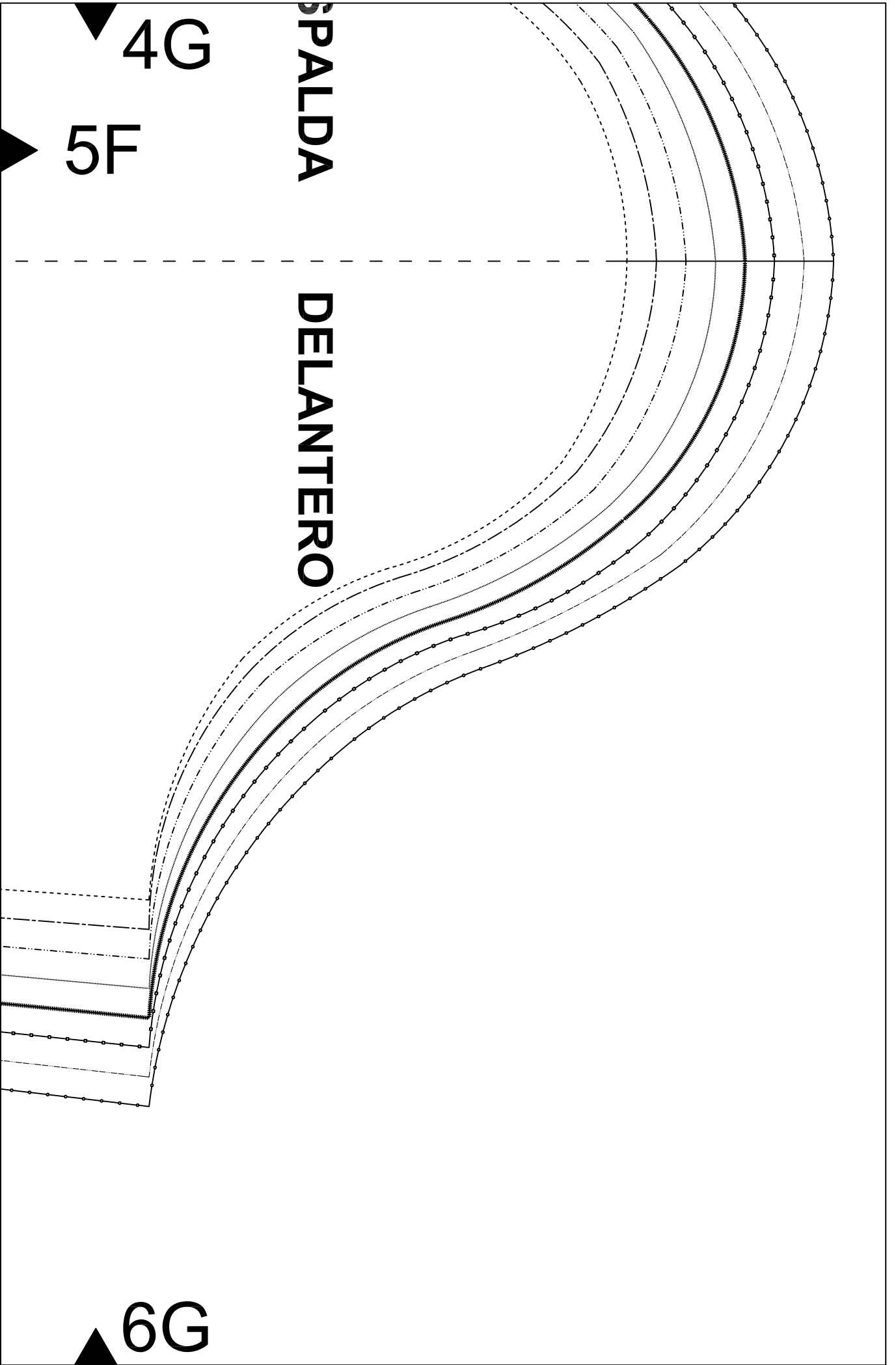



6A

7A

6B

7A

7B

HILO



6C

7B

7C

LOMO

▼ 6D

▶ 7C

7D ◀

PATRÓN VESTIDO EVASÉ

DELANTERO

1 x TEJIDO

6E

7D

7E

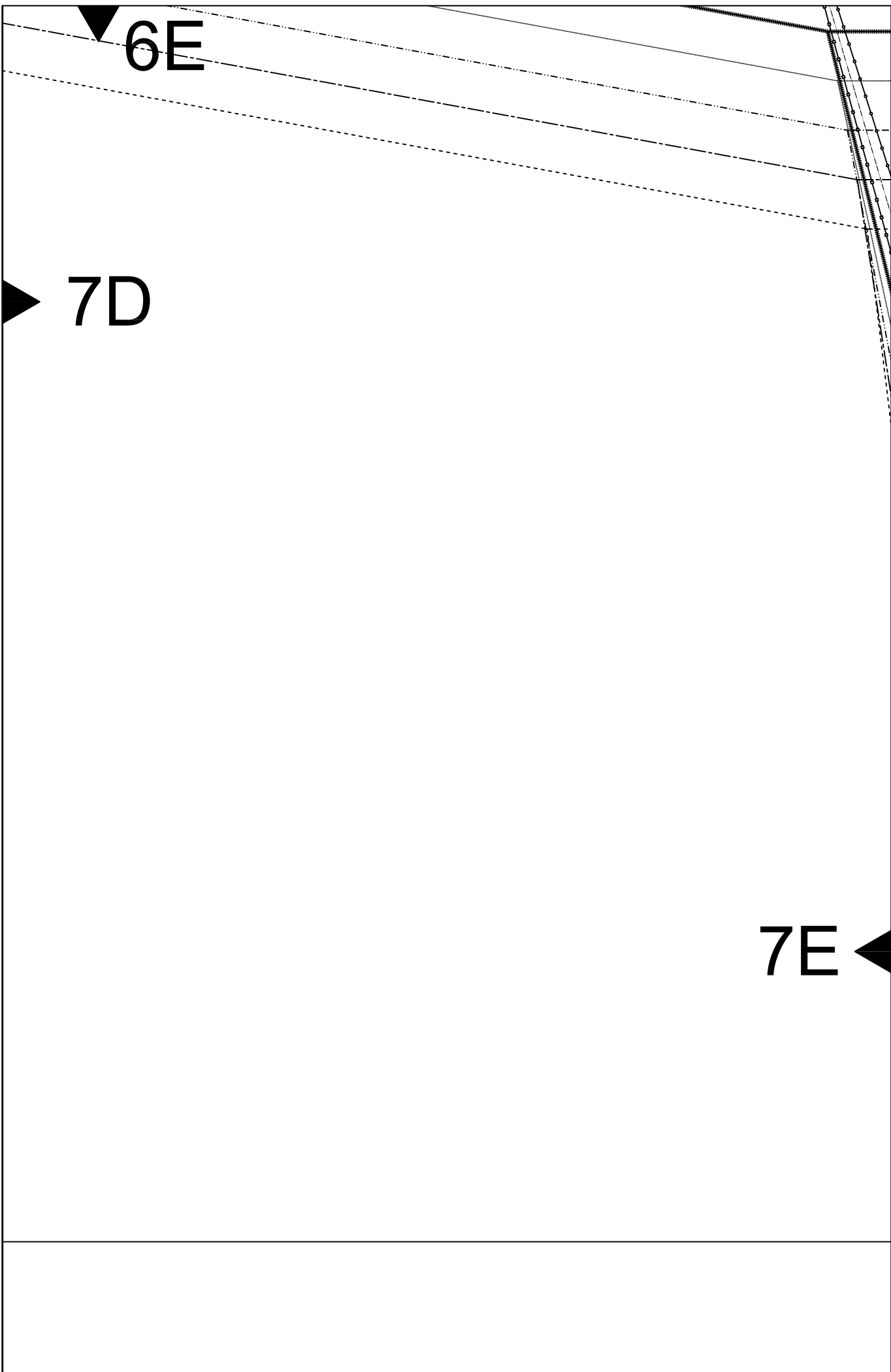

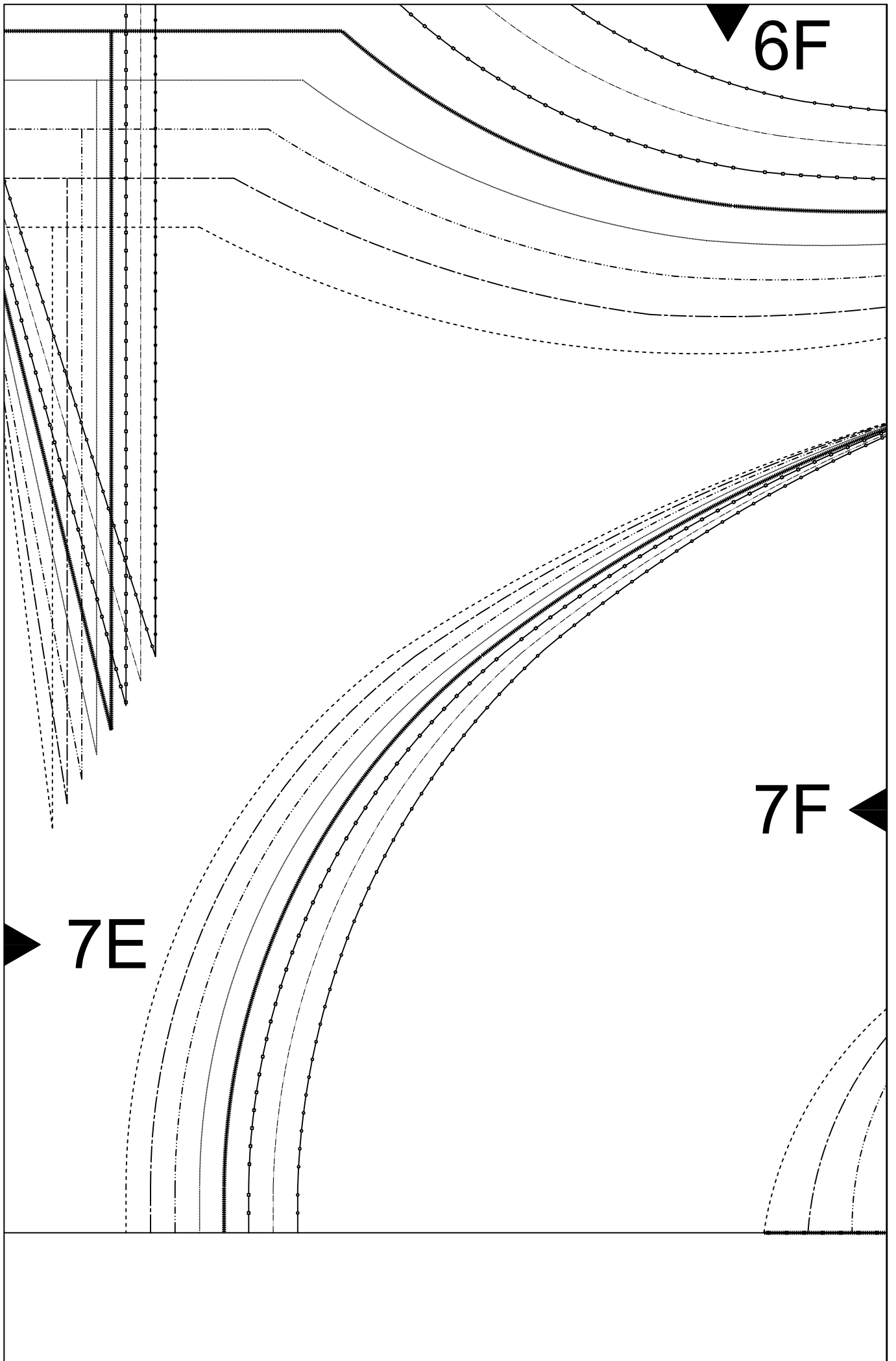

6G

7F

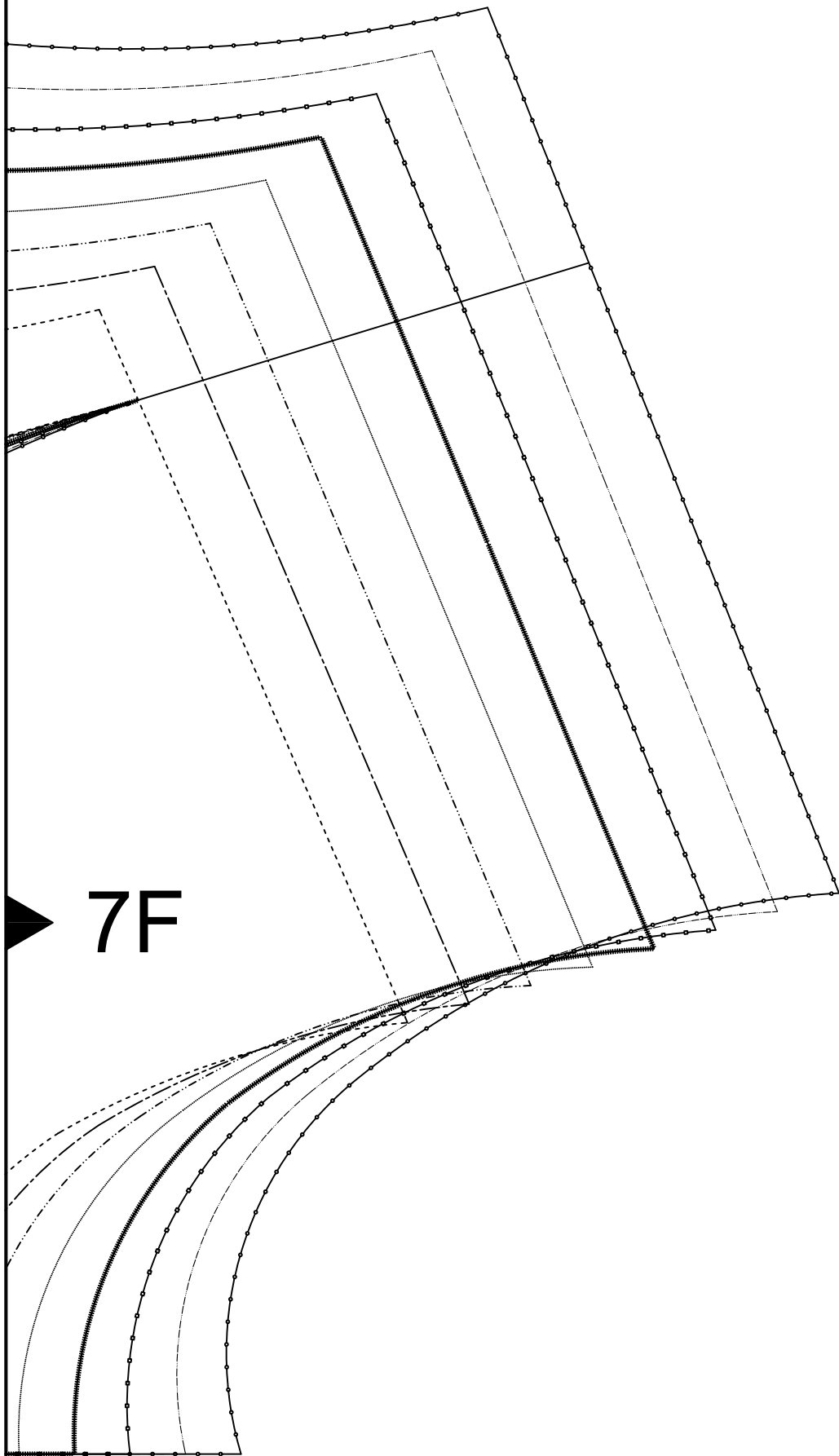



LEYENDA TALLAS

-----	TALLA 36
-----	TALLA 38
-----	TALLA 40
-----	TALLA 42
=====	TALLA 44
-----	TALLA 46
-----	TALLA 48
-----	TALLA 50
-----	COMÚN A TODAS LAS TALLAS

TEST COMPROBACIÓN
MEDIDAS

CUADRADO DE MEDIDAS
10 cm x 10 cm